

Revised Date: June 6, 2006

UP2202

Data Sheet

(Preliminary)

Doc. #: DS-2202-01
<Rev. 0.3>

The content of this technical information is subject to change without notice.
Please contact UBEC for further information.

All rights strictly reserved. Any portion of this paper shall not be reproduced, copied, or transformed to any other forms without permission from Uniband Electronic Corp.

Uniband Electronic Corp.

3F-3, No. 192, Dongguang Rd., Hsinchu 300, Taiwan

TEL: +886-3-5729898

FAX: +886-3-5718599

http:// www.ubec.com.tw

Table of Contents

1	Product Description	4
2	Features	4
3	Applications	4
4	Pin Description	5
5	Package Specification	6
6	Absolute Maximum Ratings.....	7
7	Key Electrical Characteristics	7
8	Performance Data	9
9	Typical Application Circuit.....	12

UBEC confidential
*** 060606 ***

Revision History

Revision	Date	Description of Change
0.0	October 26, 2005	Original.
0.1	January 11, 2006	Include WLAN testing result
0.2	February 23, 2006	Modify package dimension.
0.3	June 6, 2006	Modify application circuit.

UBEC confidential
*** 060606 ***

DISCLAIMER

ALTHOUGH TO THE BEST KNOWLEDGE OF THE UNIBAND ELECTRONIC CORPORATION (UBEC) THIS DOCUMENT IS ADEQUATE FOR ITS INTENDED PURPOSES, UBEC MAKES NO WARRANTY OF ANY KIND WITH REGARD TO ITS COMPLETENESS AND ACCURACY. UBEC EXPRESSLY DISCLAIMS ANY AND ALL OTHER WARRANTIES, EXPRESS, IMPLIED, OR STATUTORY INCLUDING WITHOUT LIMITATION WARRANTIES OF TITLE, MERCHANTABILITY, NON-INFRINGEMENT, AND FITNESS FOR A PARTICULAR PURPOSE, WHETHER ARISING IN LAW, CUSTOM, CONDUCT OR OTHERWISE.

1 Product Description

The UP2202 is a high efficiency, linear power amplifier IC designed for 2.4GHz applications such as WLAN (802.11b/g), Bluetooth and other ISM-band applications. UP2202 is designed to provide excellent linearity and efficiency over a wide range of supply voltage and output power. The device is fabricated on an advanced GaAs/InGaP HBT process and packaged in a 2mmX2mm, 8pin, QFN with a bottom ground.

2 Features

Single 3.3V supply

- 23 dBm P1dB output power
- 26 dB linear gain
- 40 dBc harmonic suppression at 20 dBm output power
- 95 mA at 20 dBm output power
- 60 mA at 15 dBm output power
- 50 ohm internally matched input

For WLAN application

- 27 dBm P1dB output power
- 29 dB linear gain
- 2.2% EVM at 18 dBm output power for 802.11g, 54Mbps, OFDM
- 135 mA at 18 dBm output power

Single 2.5V supply

- 23 dBm P1dB output power
- 19 dB linear gain
- 38 dBc harmonic suppression at 13 dBm output power
- 13 mA at 13 dBm output power
- 50 ohm internally matched input

3 Applications

- Bluetooth
- WLAN
- 2.4 GHz ISM band
- 2.4 GHz wireless earphone

4 Pin Description

Top View

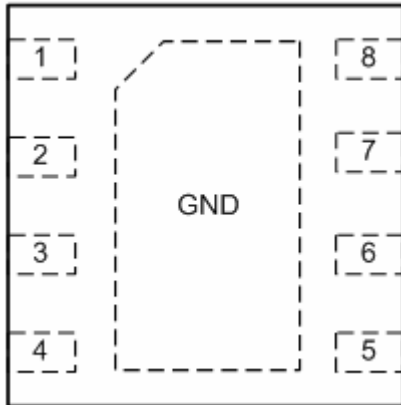

Pin #	Name	Description
1	Vpc1	Power control for PA 1 st stage
2	RFin	RF input
3	Vcc1	Power supply for PA 1 st stage
4	Rb2	Bias control resistor
5	Vpc2	Power control for PA 2 nd stage
6	Vb2	Power supply for PA bias 2 nd stage
7	Vcc2+Rfout	Power supply for PA and RF out
8	Vb1	power supply for PA bias 1 st stage

UBEC confidential
 *** 060606 ***

5 Package Specification

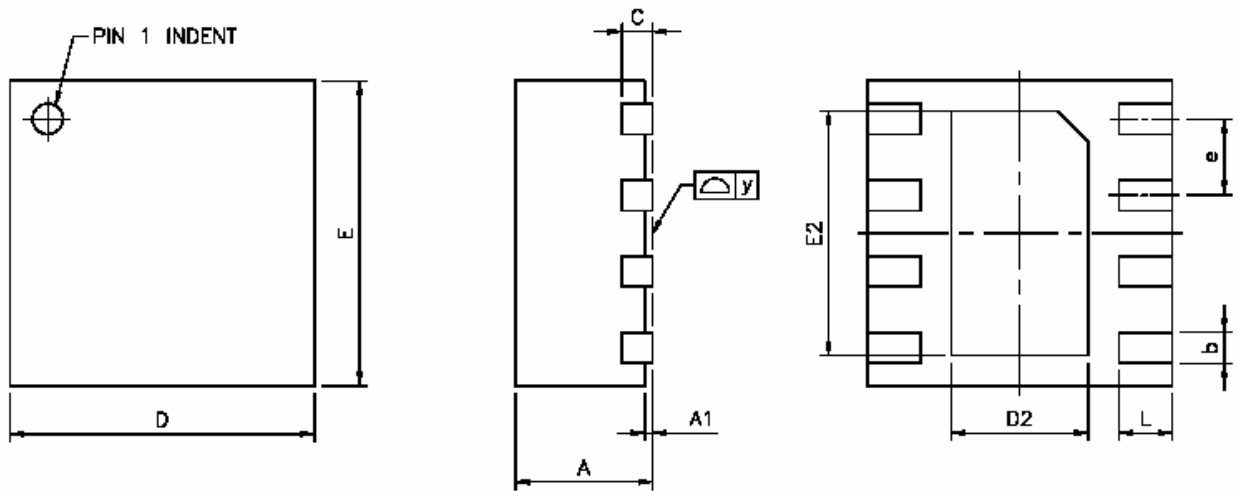

Symbols	Dimensions in Millimeters		
	Min.	Nom.	Max.
A	0.80	0.9.	1.00
A1	0.00	0.02	0.05
b	0.15	0.20	0.25
C	0.19	0.20	0.25
D	1.90	2.00	2.10
D2	0.85	0.90	0.95
E	1.90	2.00	2.10
E2	1.55	1.80	1.65
e	-----	0.5	-----
L	0.30	0.35	0.40
y	0.00	-----	0.075

6 Absolute Maximum Ratings

Items	Value	Unit
Supply voltage	6	V
Power control voltage	3.5	V
RF input power	5	dBm
Operating case temperature	-30 to 80	°C
Storage temperature	-30 to 120	°C

7 Key Electrical Characteristics

*Vcc connected to 3.3 V

Items	Conditions	Min.	Typ.	Max.	Unit
Operating Power Supply Voltage		3.0	3.3	4.3	V
Frequency Range		2.40	----	2.50	GHz
Quiescent Current	at Vpc = 2.8V	----	24	----	mA
Current Consumption	Pout=20dBm; Efficiency=32%	----	95	----	mA
Linear Gain		----	26	----	dB
Pout at 1dB Gain Compression		----	23	----	dBm
Input Return Loss		----	12	----	dB
Power Control - Enable		----	2.8	----	V
Power Control - Disable		----	----	0.5	V
Max. Power Control Current				4	mA
Power Down Current	Vpc=0V	----	0.2	----	uA
Output Harmonics Suppression	Pout=20dBm	----	-40	----	dBc



Caution: ESD sensitive.

*Vcc, Vpc1, Vpc2, Vb1, Vb2 all connected to 3.3 V, for WLAN 802.11b/g application

Items	Conditions	Min.	Typ.	Max.	Unit
Operating Power Supply Voltage		3.0	3.3	4.3	V
Frequency Range		2.4	2.45	2.5	GHz
Quiescent Current		85	95	110	mA
Current Consumption	Pout =18 dBm; EVM<2.2%	-----	135	145	mA
Linear Gain		28	29	30	dB
Pout at 1dB Gain Compression		26.5	27	-----	dBm
Input Return Loss		10	13	-----	dB
Power Control - Enable		3.0	3.3	-----	V
Power Control - Disable		-----	-----	0.5	V
Max. Power Control Current				4	mA
Power Down Current	V _{PC} =0V	-----	40	80	uA
Max Linear Output Power	I _{total} =136 mA; EVM=3.6%	19	-----	-----	dBm
Output Harmonics Suppression		-----	-40	-----	dBc
Adjacent Channel Power 1 Rejection	Pout=21 dBm, CCK/ 11 Mbps	-----	-36	-----	dBr
Adjacent Channel Power 2 Rejection	Pout=21 dBm, CCK/ 11 Mbps	-----	-57	-----	dBr



Caution: ESD sensitive.

UBECE confidential
 *** 060606 ***

8 Performance Data

* Vcc, Vpc1, Vpc2, Vb1, Vb2 are all connected to 3.3 V, T=25°C for WLAN 802.11b/g application.

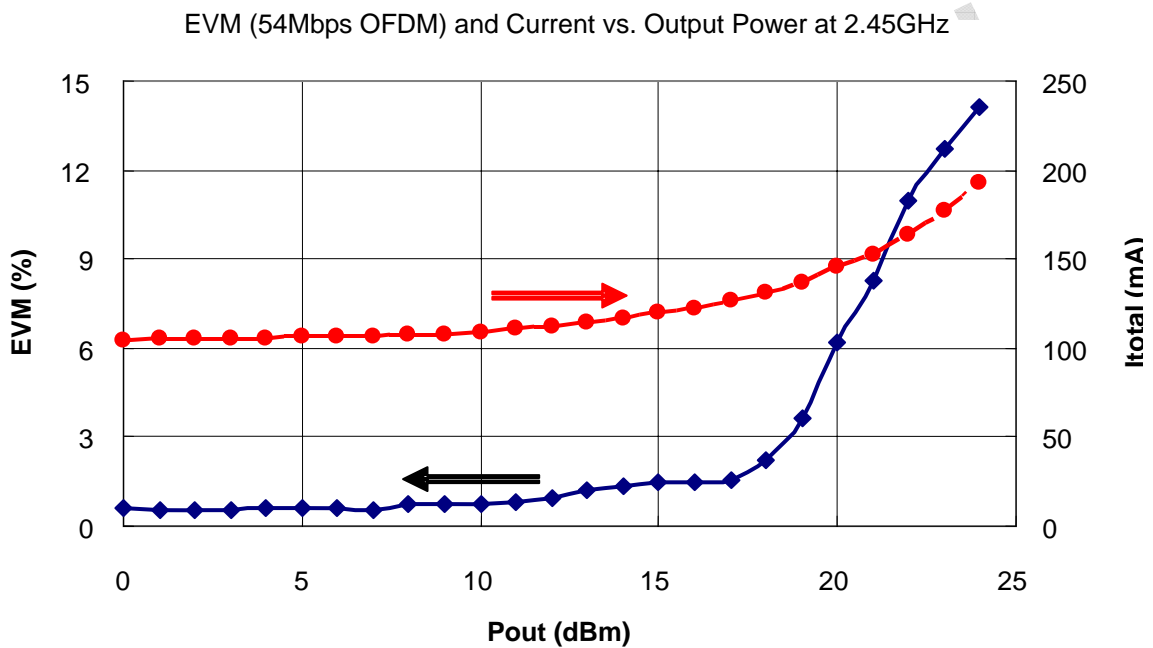
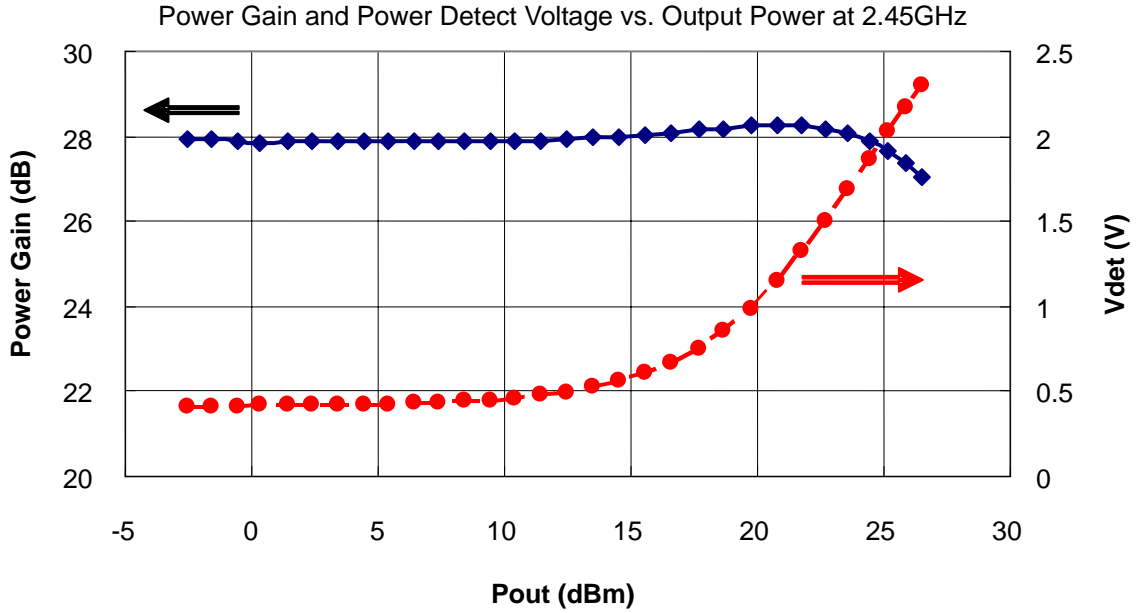

EVM (54Mbps OFDM) and Output Power vs. Vpc1/Vpc2 at 2.45GHz

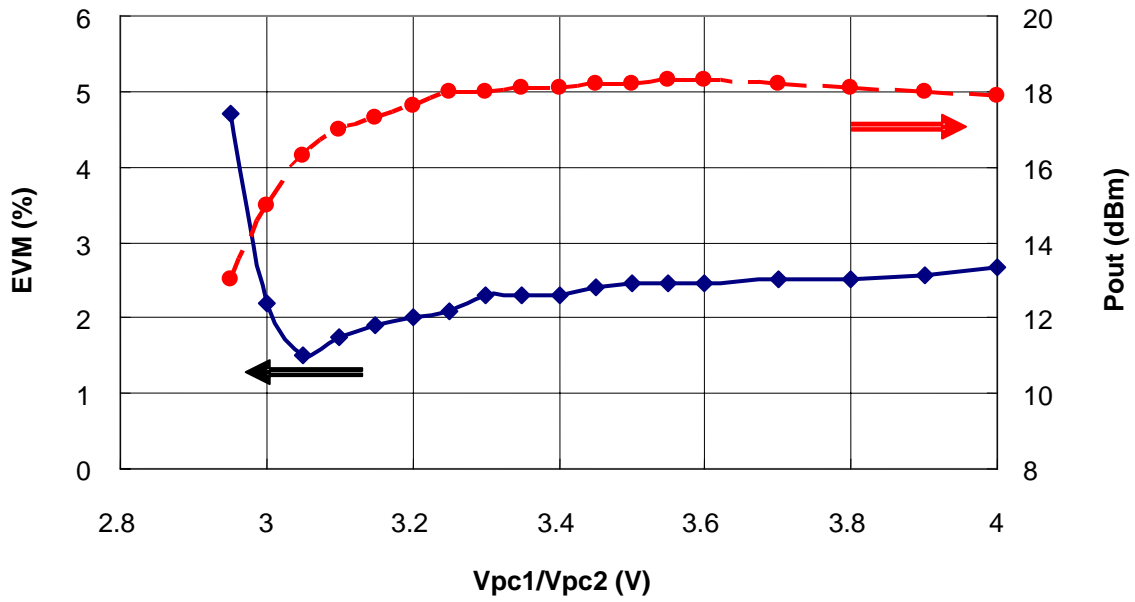

Current and Output Power vs. Vpc1/Vpc2 at 2.45GHz

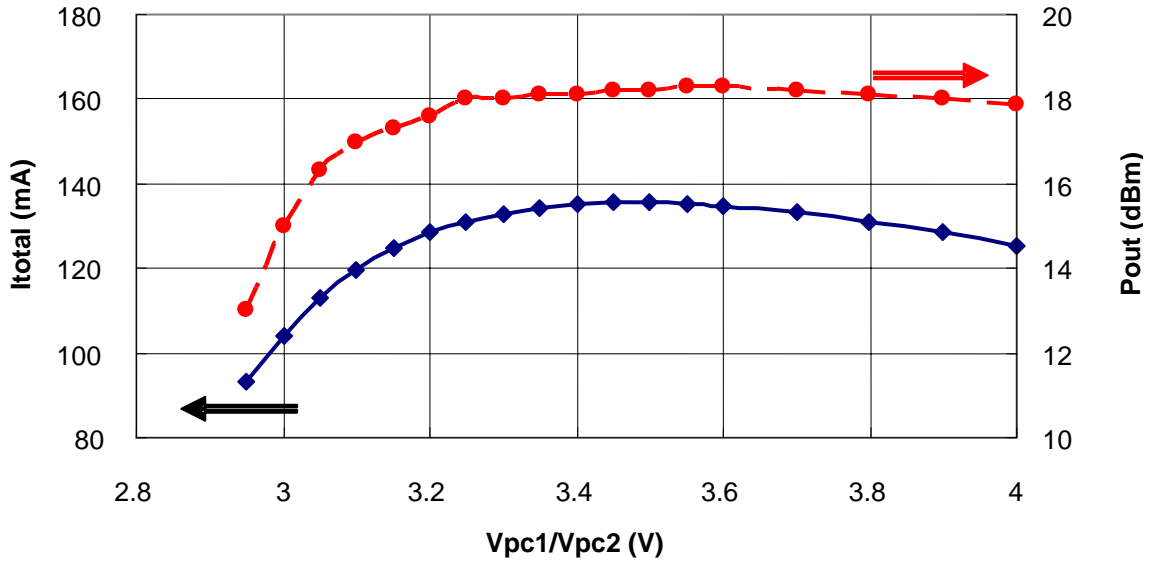

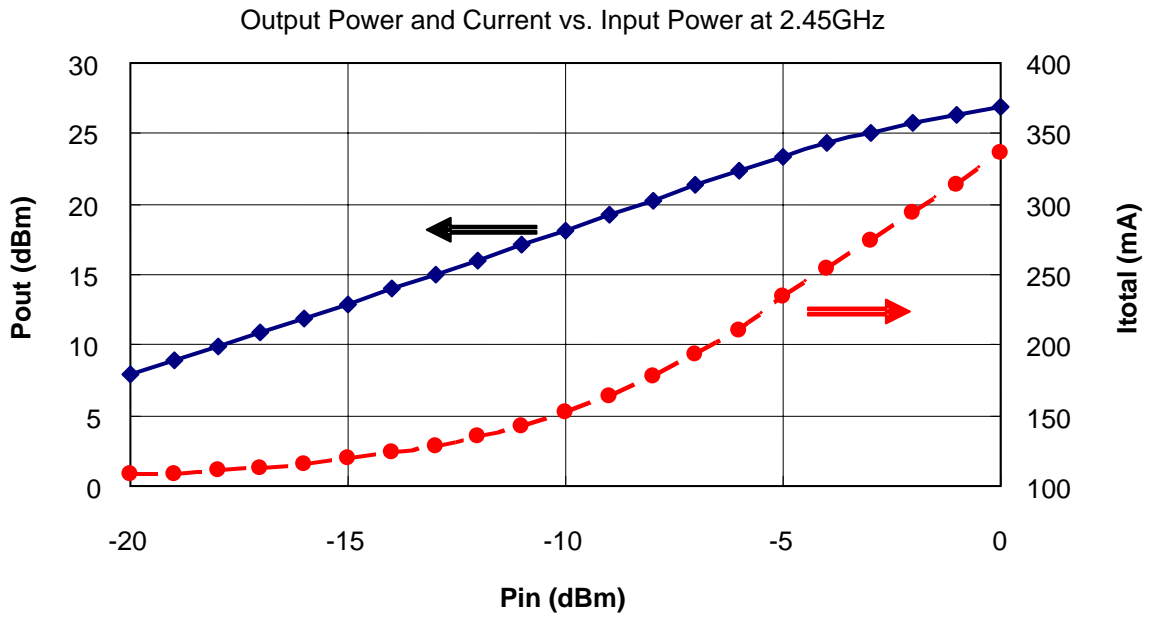

UBEC confidential
*** 060606 ***

9 Typical Application Circuit

For Bluetooth application

Vcc =3.3 V

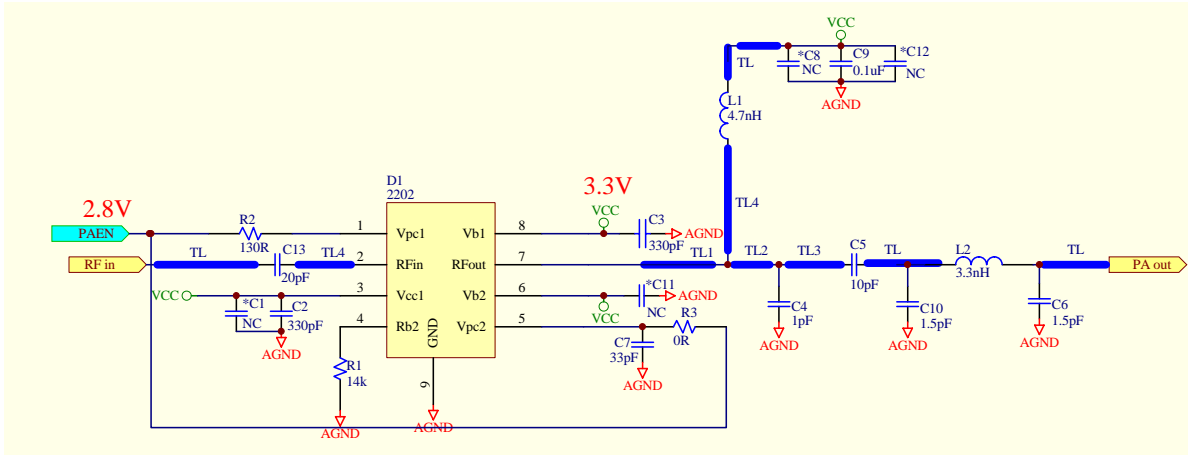

All TL are 50 ohm lines

	TL1	TL2	TL3	TL4
Length (mil)	<8	32	24~80	24~40

* Note 1: *C1, *C12, *C8, *C11 for optional components rely on PCB tuning.

UBEC confidential
*** 060606 ***

For WLAN and Bluetooth EDR 2.0 application

Vcc =3.3 V

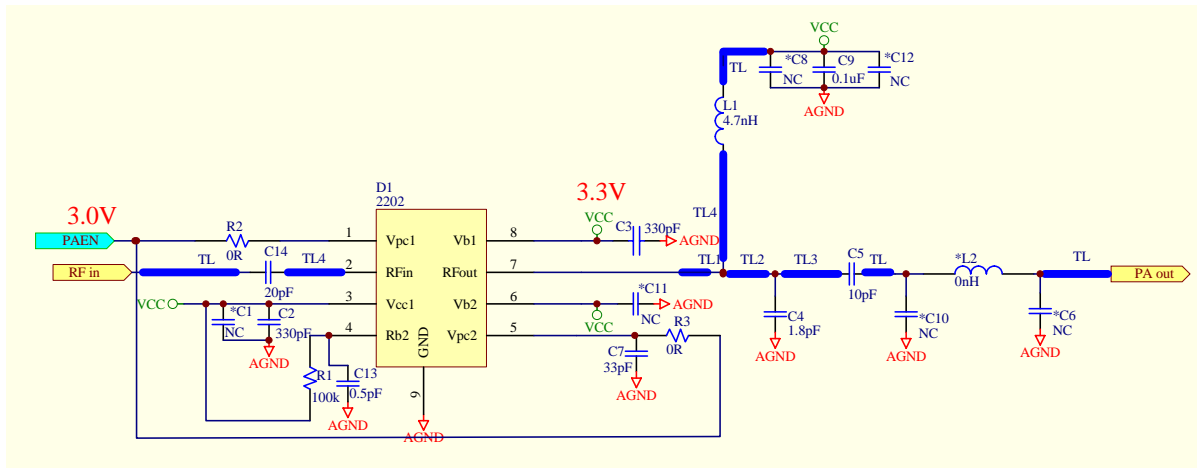

All TL are 50 ohm lines

	TL1	TL2	TL3	TL4
Length (mil)	<8	32	24~80	24~40

* Note 1: *C1, *C12, *C8, *C11 for optional components rely on PCB tuning

* Note 2: *C10, *C6, *L2 for optional components to improve harmonic suppression.

Ubec confidential
 *** 060606 ***

10 PCB Stack Structure

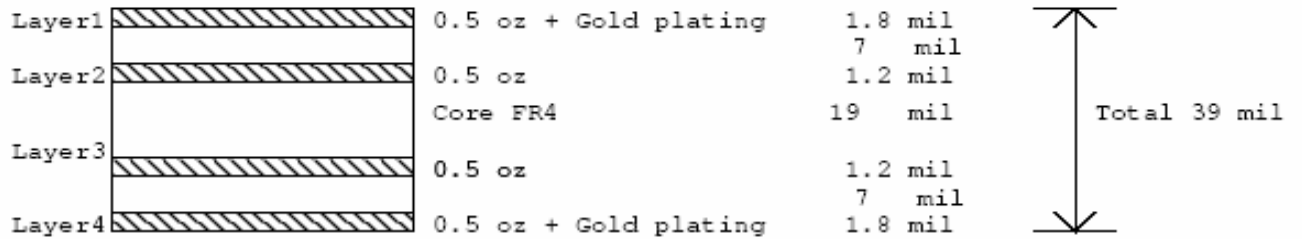

- 50 ohm line width is 12 mil, and spacing is 12mil.

UBEC confidential
 *** 060606 ***

11 Evaluation Board Layout

Board Thickness 39mil; Board Material FR-4; Multi-Layer

Full

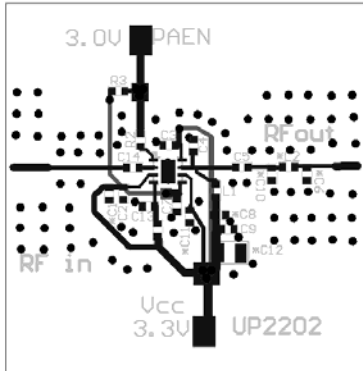

Top Layer

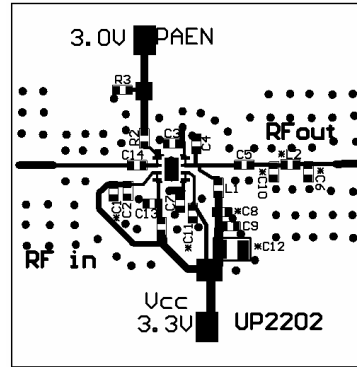

Second Layer

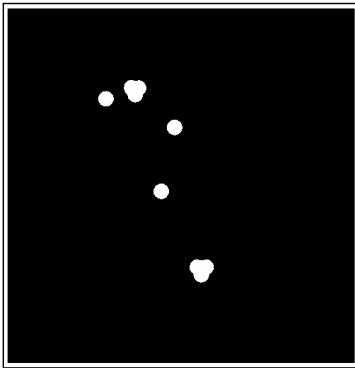

Third Layer

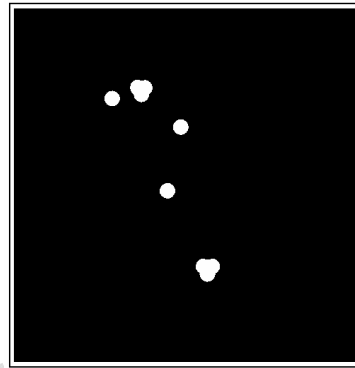

Bottom Layer

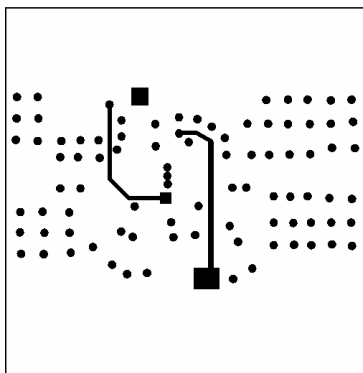

CONFIDENTIAL
060606